

Wheel Alignment

Check

[How to use this manual.](#)

1. Pre-Alignment - Check

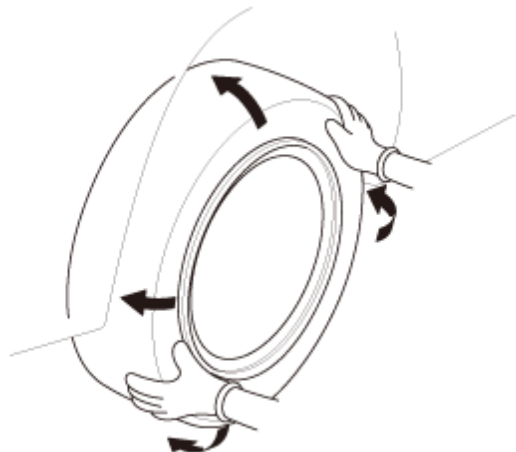

■ Procedure

For proper inspection and adjustment of the wheel alignment, do these checks:

1. Release the parking brake to avoid an incorrect measurement.
2. Make sure the suspension is not modified.
3. Make sure the fuel tank is full, and that the spare tire or the temporary repair kit, jack, and tools are in place inside the vehicle.
4. Check the tire size and tire pressure according to the tire information.
5. Set the steering column to the middle tilt position and telescopic position (if equipped).
6. [Check the runout of the wheels and tires.](#)
7. Check the suspension ball joints ([Raise and support the vehicle](#). Hold a tire with your hands, and move it up and down and right and left to check for movement).
8. Before doing alignment inspections, be sure to remove all extra weight from the vehicle, and no one should be inside the vehicle (driver or passengers).
9. Lower the vehicle to the ground. Bounce the vehicle up and down several times to stabilize the suspension.

Inspection

[How to use this manual.](#)

Use a commercially available computerized four wheel alignment equipment to measure wheel alignment (caster, camber, toe, and turning angle). Follow the equipment manufacturer's instructions.

1. Caster - Inspect

■ Procedure/Specifications

- Check the caster angle.

Specifications

Item	Type	Standard Value
Front Caster Angle	Except Si and Type-R	5 ° 17 ' ± 30 '
	Si	5 ° 20 ' ± 30 '
	Type-R	7 ° 41 ' ± 30 '

■ Result

- If the measurement is not within specifications, check for bent or damaged suspension components.

■ After Inspection

- Inspect the camber angle.

2. Camber - Inspect

■ Procedure/Specifications

- Check the camber angle.

Specifications

Item	Type	Standard Value
Front Camber Angle	Except Si and Type-R	-0 ° 18 ' ± 30 '
	Si	-0 ° 21 ' ± 30 '
	Type-R	-1 ° 30 ' ± 30 '
Maximum Difference Between Right and Left Side (Front)	Except Type-R	0 ° ± 40 '
	Type-R	0 ° ± 30 '
Rear Camber Angle	Except Si and Type-R	-1 ° 12 ' ± 45 '
	Si	-1 ° 20 ' ± 45 '
	Type-R	-1 ° 30 ' ± 45 '
Maximum Difference Between Right and Left Side (Rear)	All models	0 ° ± 45 '

■ Result

- If the measurement is not within specifications, check for bent or damaged suspension components.

■ **After Inspection**

- Inspect the rear toe.

3. Rear Toe - Inspect

NOTE: Do the rear toe inspection before the front toe inspection.

■ **Preconditions**

- Parking Brake Released

NOTE: If the automatic parking brake function is turned on, [do the temporarily cancel automatic electric parking brake.](#)

■ **Procedure/Specifications**

- Check the rear toe.

Specifications

Item	Standard Value
Rear Total Toe-In	2 ⁺² ₋₁ mm (0.08 ^{+0.08} _{-0.04} in)

■ **Result**

- If the measurement is not within specifications, adjust the rear toe adjustment.

■ **After Inspection**

- Inspect the front toe.

4. Front Toe - Inspect

NOTE: Do the rear toe inspection before the front toe inspection.

■ **Procedure/Specifications**

1. Center the steering wheel spokes, and hold it.

- 2. Check the front toe with the wheels pointed straight ahead.

Specifications

Item	Type	Standard Value
Front Total Toe-In	Except Type-R	1 ± 2 mm (0.04 ± 0.08 in)
	Type-R	0 ⁺² ₋₁ mm (0 ^{+0.08} _{-0.04} in)

■ Result

- If the measurement is not within specifications, adjust the front toe.

■ After Inspection

- Inspect the turning angle.

5. Turning Angle - Inspect

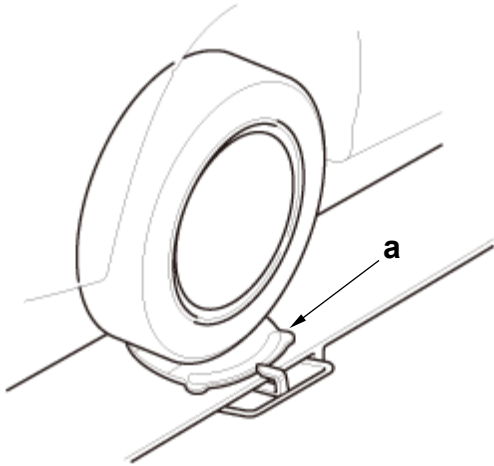

■ Procedure/Specifications

- Turn the wheel right and left while applying the brake, and measure the turning angle of both wheels.

Tool Details

Name	
a	Turning Radius Gauge

Specifications

Item	Type	Wheel Size	Standard Value
Turning Angle Inward	Except Si and Type-R	Without 18 inch wheels	39 ° 58 ' ± 2 °
		With 18 inch wheels	36 ° 58 ' ± 2 °
	Si	All wheels	36 ° 46 ' ± 2 °
	Type-R	All wheels	35 ° 36 ' ± 2 °
Turning Angle Outward (reference)	Except Si and Type-R	Without 18 inch wheels	33 ° 04 ' ± 1 °
		With 18 inch wheels	31 ° 19 ' ± 1 °
	Si	All wheels	31 ° 12 ' ± 1 °
	Type-R	All wheels	29 ° 50 ' ± 1 °

■ Result

- If the measurement is not within specifications, even up both sides of the tie-rod threaded section while adjusting the front toe. If they are even, but the turning angle is not within the specifications, check for bent or damaged suspension components.

Adjustment

[How to use this manual.](#)

NOTE:

- The suspension can be adjusted for front camber, front toe, and rear toe. However, each of these adjustments are related to each other. For example, when you adjust camber, the toe will change.
- After adjusting the wheel alignment, [do the VSA sensor neutral position memorization.](#)

1. Front Camber - Adjust

■ Preconditions

- [Vehicle Lifted](#)

Figure 1 (Screw guide pin type)

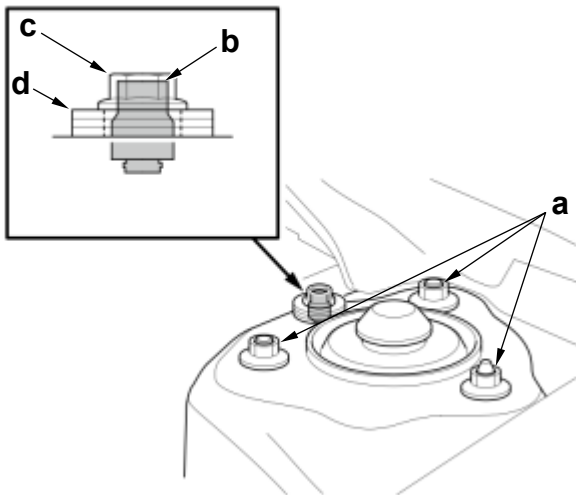

■ Procedure/Specifications

1. Replace the nuts (a) with new ones, and lightly tighten them. (Figure 1 and 2)
2. If the guide pin (b) is equipped, remove it by doing the following. (Figure 1 and 2)

NOTE: The guide pin is for factory assembly use only and can be discarded after removal.

• Screw guide pin type

Install a suitable nut (c) with 2-3 suitable washers (d) to the guide pin, then tighten the nut until the guide pin comes off. (Figure 1)

• Hex guide pin type

Figure 2 (Hex guide pin type)

Use a wrench (e) to rock the guide pin left and right while pulling it out from the damper mounting base (f). (Figure 2)

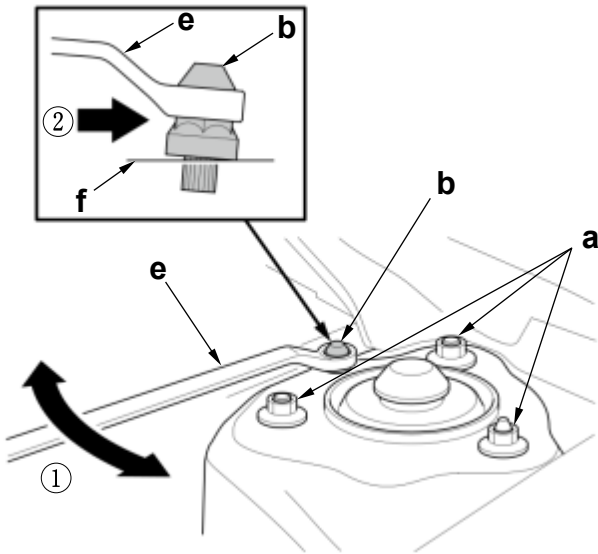
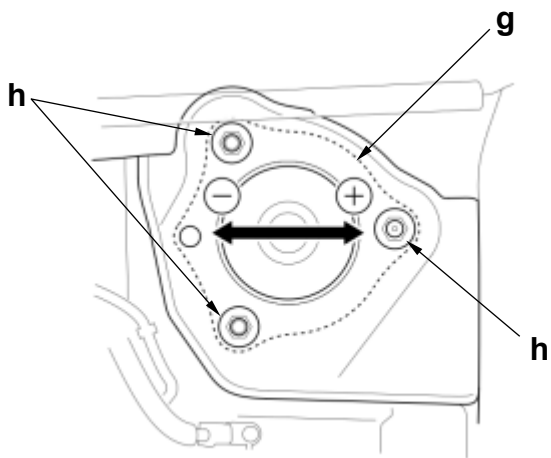

Figure 3



- Adjust the camber angle by moving the upper part of the damper (g). (Figure 3)

NOTE: The camber angle can be adjusted $\pm 19'$.

- [Tighten the nuts \(h\) to the specified torque.](#) (Figure 3)
- Lower the vehicle to the ground, and bounce the front of the vehicle up and down several times to stabilize the suspension.
- Measure the camber angle. If the camber angle is not within specification, readjust the camber angle. If the camber measurement is correct, measure toe-in, and adjust it if necessary.

Figure 4

- Install the hole seal (i) after the guide pin is removed. (Figure 4)

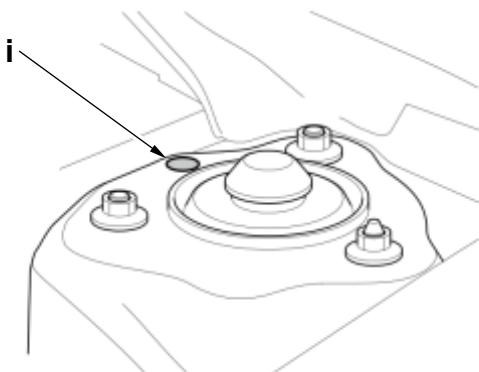

NOTE: Refer to the Parts Catalog for the hole seal.

■ After Adjustment

- [VSA Sensor Neutral Position Memorization](#)

2. Front Toe - Adjust

■ Preconditions

- [Vehicle Lifted](#) (As needed)

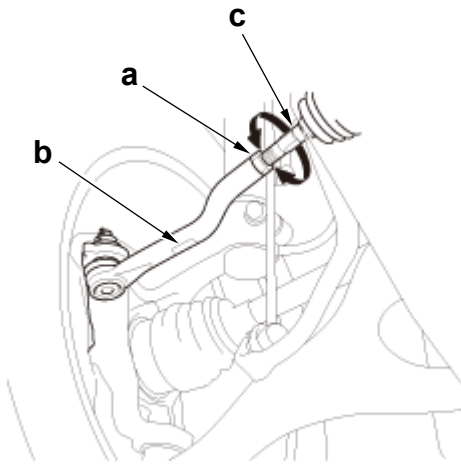

■ Procedure/Specifications

1. Loosen the nuts (a) while holding the flat surface (b) of the tie-rod end with a wrench, and turn both tie-rods (c) until the front toe is within specifications.
2. After adjusting, [tighten the nuts to the specified torque](#).

NOTE: Reposition the boot if it is twisted or displaced.

■ After Adjustment

- [VSA Sensor Neutral Position Memorization](#)

3. Rear Toe - Adjust

■ Preconditions

- [Vehicle Lifted](#)

■ Procedure/Specifications

1. Hold the adjusting bolt (a) on the lower arm B (b), and remove the nut (c).

2. Replace the nut with a new one, and lightly tighten it.

NOTE:

- Always use a new nut whenever it has been loosened.
- Reassemble the bolt and the adjusting cam plate with the eccentric facing up.

3. Adjust the rear toe by turning the adjusting bolt until the toe is correct.

4. [Tighten the nut to the specified torque](#) while holding the bolt.

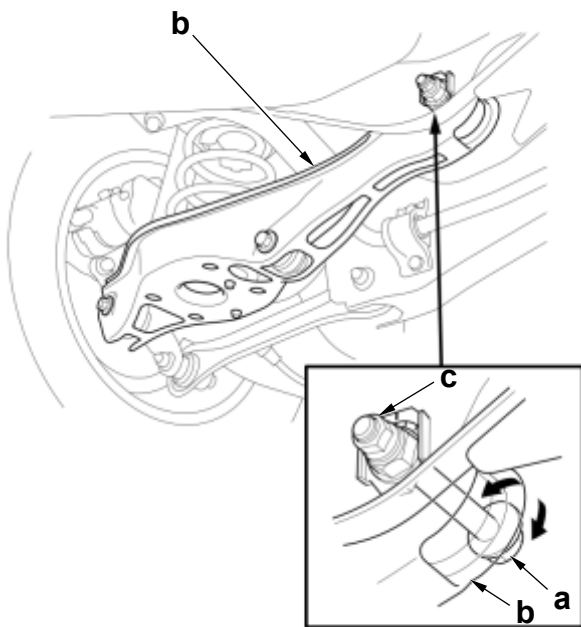

■ After Adjustment

- [VSA Sensor Neutral Position Memorization](#)